

## Attention! General warnings!

Read this manual carefully before assembling and using the product. This product is exclusively intended for use in private domains in accordance with this manual and may not be used for commercial purposes. Any other form of use constitutes improper use and can result in material damage and even personal injury. The manufacturer does not accept any liability for damage caused due to improper use. Do not use the product if it appears to be damaged in any way. Do not leave children unattended near the product. The product is intended for indoor use only. Do not use in humid rooms or near water. Avoid using locations where shock and vibrations could occur. The product may only be burdened up to the specified maximum weight (25kg). The package contains small parts. Keep away from the reach of small children. The product should be placed in an area where there is no possibility for the product to be tipped over.

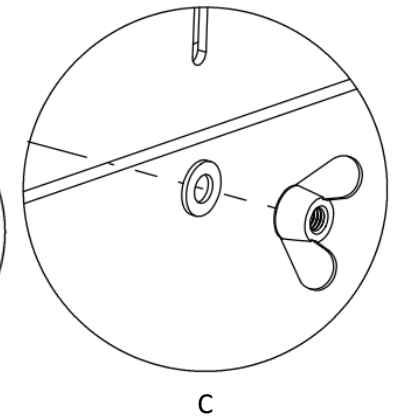
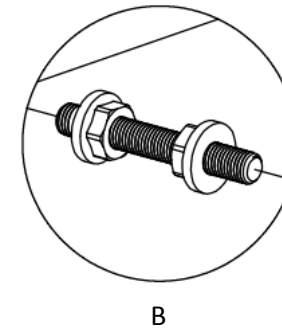
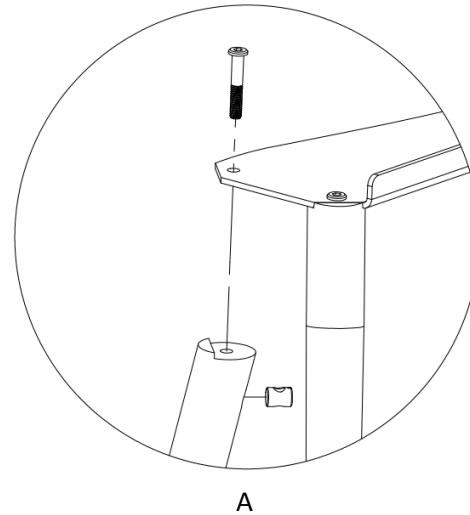
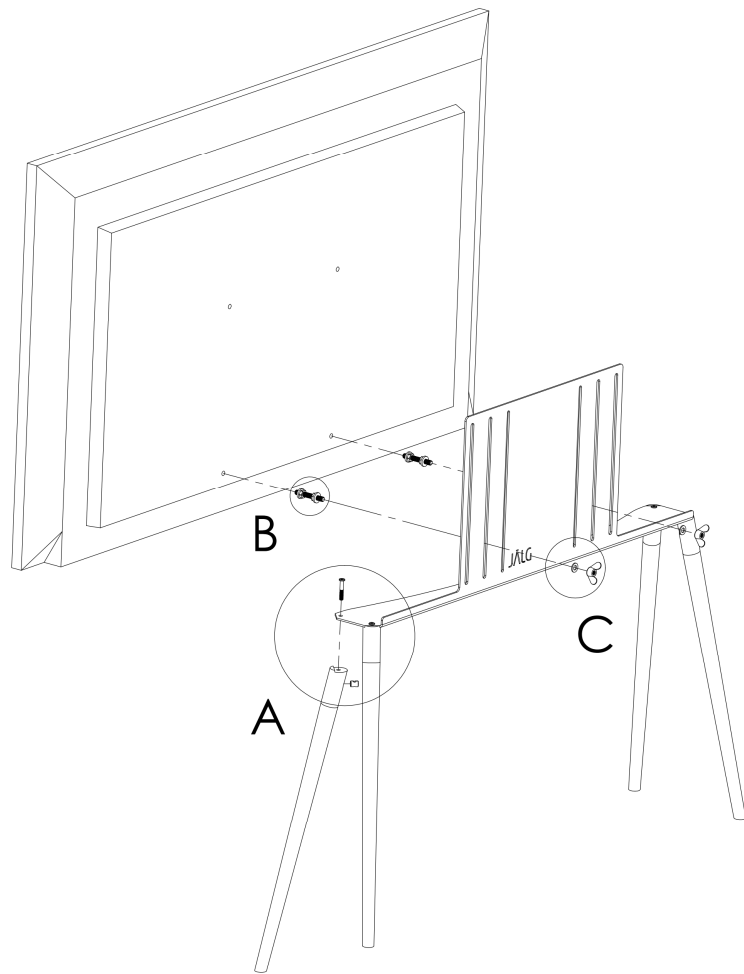

### Step 1.

With the frame laying flat on the ground, assemble the legs to the frame. (Figure A.)

### Step 2.

Attach the threaded rods to the lower VESA holes on the TV and fix them with contra nuts. Screw the distance adjustment nut on the threaded rod. (Figure B.) Use M6 or M8 threaded rods and nuts as necessary.

### Step 3

Place the TV on the stand with the threaded rods going through the vertical grooves. Align the front of the TV with the front of the stand using adjustment nuts. Attach the fixing nut on the threaded rod. (Figure C.)